

# Severity-Based Tactical Conflict Detection in Terminal Airspace

Huabin Tang<sup>1</sup>

*NASA Ames Research Center, Moffett Field, CA 94035*

A method for determining the severity of impending losses of separation (LOSs) is proposed. It is based on the FAA (Federal Aviation Administration) separation conformance category for classification of operational errors. A recently proposed short-term conflict detection algorithm for terminal airspace is enhanced with this severity concept. The alerts from the resulting algorithm are compared with the Conflict Alert (CA) currently in the field, which is a legacy system for automated short-term conflict detection. Three complementary sets of aircraft track data are employed. The first set is real-world data with documented LOSs due to operational errors. It allows determination of average alert lead time while providing regression testing of the algorithm. The second set is realistic data from human-in-the-loop experiments with no visual approaches allowed and with known intervention from controllers or pilots available. As a result more objective determination of false alert rate is possible. The third set is real-world data with unknown mixed operations of Instrument Landing System (ILS) and visual approaches but with CA alerting data available from the FAA. The comparison with CA indicates that the algorithm produces a similar total number of alerts but with a much larger safety buffer and a much lower false alert rate. The study also suggests that a high-severity conflict prediction option may be used for aircraft performing visual approaches to satisfy the controller's moral responsibility for those aircraft.

## I. Introduction

AIR traffic systems have long relied on automated short-term conflict prediction algorithms to warn controllers of impending conflicts (losses of separation). The complexity of terminal airspace has proven difficult for such algorithms. The contributing factors include dense air traffic, frequent large turns, and insufficient specific route details in the flight plans, as well as the frequent necessity to operate aircraft purposely near the required, complex separation standards. Conflict Alert<sup>1</sup> (CA), a legacy system that has been used in the field for over 30 years, currently provides tactical alerts in terminal airspace. CA is mainly based on dead reckoning for aircraft trajectory predictions, and it alerts when an aircraft is in dangerous proximity of another aircraft, which typically corresponds to separation thresholds of about a few hundred feet vertically and one nautical mile horizontally. Analysis of CA alerts by Friedman-Berg et al.<sup>2</sup> showed that about 80% of the alerts in terminal airspace do not provide useful information to controllers and are thus nuisance alerts. Friedman-Berg et al. also suggested the usage of flight intent information in terminal automation systems as in en route systems to reduce nuisance alerts.

There has been considerable research directed towards a new concept for automated separation assurance, referred to as the Advanced Airspace Concept (AAC).<sup>3-5</sup> The AAC provides two independent layers of separation assurance - a strategic layer and a tactical layer. The strategic layer focuses on mid-term conflicts predicted to be from 2 to 20 minutes into the future. The tactical layer addresses short-term or imminent conflicts predicted to occur within approximately 2 minutes. A third layer of safety is provided by an independent airborne collision avoidance system such as TCAS (Traffic Alert and Collision Avoidance System).<sup>6</sup> TCAS deals with potential collisions less than approximately 45 seconds away. The tactical layer, known as Tactical Separation Assured Flight Environment (TSAFE), is proposed as a backup system that duplicates a limited set of safety-critical functions of the strategic layer. TSAFE has also been envisioned as a near-term standalone tool to aid controllers with short-term conflict detection and resolution. TSAFE adopts both flight plan and dead reckoning flight trajectories to probe for potential

---

<sup>1</sup> Aerospace Engineer, AFA 210-6, Moffett Field, CA 94035, huabin.tang-1@nasa.gov.

conflicts.<sup>5</sup> En-route prototypes of TSAFE have been developed and studied with the use of en-route operational error cases.<sup>7-10</sup> TSAFE conflict resolution has also been studied.<sup>11-13</sup>

Recently a conflict detection algorithm that incorporates flight intent information in the trajectory predictions was proposed,<sup>14</sup> which yields a small false alert rate while providing generally sufficient alert lead time to controllers. The algorithm uses a single deterministic trajectory that follows available flight intent and reduces to the dead reckoning trajectory when no flight intent information is available. Losses of separation have been defined in terms of the separation standards for terminal airspace, including wake separation requirements. False alert rate was studied with three 30-minute sets of recent real-world data of arrival and departure operations from Dallas/Fort Worth (DFW) Terminal Radar Approach Control (TRACON). Alert lead time was also analyzed from data of aircraft pairs of 70 operational error cases from DFW TRACON. It was shown that the algorithm significantly reduced false alert rate while maintaining an acceptable average alert lead time, when compared to a model adapting the en-route TSAFE dual-trajectory algorithm to terminal airspace, and a model using mostly dead-reckoning trajectories. The algorithm has also been incorporated into the Multi-Aircraft Control System (MACS) to interface with controllers in Human-In-The-Loop (HITL) experiments.<sup>15</sup> Feedback from participating controllers have been positive.

When the weather ceiling and visibility is adequate, an IFR (Instrument Flight Rule) aircraft may be cleared to follow another aircraft for visual approach. The standard separation criteria will then be inapplicable and the controller will no longer be responsible for separation of the aircraft. However, feedback from controllers suggests that they still desire to be alerted should the aircraft get unexpectedly close to each other to satisfy their moral responsibility. The study of a severity-based approach to conflict detection in this paper will address the alerting options in this situation. In other situations where IFR flights make Instrument Landing System (ILS) approaches, the controller may prefer not to get alerts too soon until the situations may develop into more severe problems. Filtering such low severity situations will reduce the potential of receiving false alerts. Here a severity-based approach will help achieve the goal.

In this paper, the conflict detection algorithm proposed in Ref. [14] is refined and enhanced to take into account the severities of impending conflicts. The severity is defined based on Federal Aviation Administration (FAA) separation conformance category for classification of operational errors, as documented in the FAA Order JO 7210.56C.<sup>16</sup> The algorithm is tested more extensively with three complementary sets of aircraft tracking data. The first set is the same as those used in Ref.[14]. It includes real-world data with documented LOSs due to operational errors and allows determination of average alert lead time as well as regression testing of the algorithm. The second set includes realistic data from HITL experiments where all aircraft make ILS approaches and records of the controller or pilot intervention are available. This allows more objective determination of the false-alert rate. The third set includes real-world data with unknown mixed operations of ILS and visual approaches, as well as CA alerts from the real Conflict Alert in the field. Comparison of the results of testing with CA alerts is performed albeit not on an equal footing because CA uses a much smaller look-ahead time and much smaller separation thresholds for alerting of aircraft getting in dangerous proximity of each other.

The rest of this paper is organized as follows. Sec. II presents an overview of the single-trajectory approach to conflict detection and defines the severity of impending conflicts as well as the severity options of conflict prediction. Sec. III describes the experimental setup and three complementary data sets used. Sec. IV shows the results of testing against the three data sets and comparison with Conflict Alert. Sec. V presents conclusions.

## II. Conflict Detection

An automated air traffic control system must provide timely and accurate prediction of impending conflicts to controllers. The definition of conflicts, the trajectory prediction algorithm, and the conflict prediction algorithm are described in this section.

### A. Definition of Conflicts

The meaning of a conflict may be very different for different tools or algorithms. A conflict in this paper is generally defined as a loss of separation, where the standard separation minima are as defined in FAA Order JO 7110.65S.<sup>17</sup>

Aircraft in terminal airspace are generally required to maintain a separation minimum of 3 n mile horizontally or 1000 ft vertically. When one of the aircraft is in en route airspace, the required

separation minimum becomes 5 n mile. When an aircraft (1) operates directly behind, that is, horizontally within 2500 ft of the flight path of the leading aircraft, and either at the same altitude as, or within 1000 ft below, the leading aircraft, or (2) follows another aircraft conducting an ILS approach, the wake turbulence separation minima in Table 1 are required. In addition, the aircraft must maintain the separation minima in Table 2 when the leading aircraft is over the runway threshold.

**Table 1 General wake separation minima for different weight classes**

Leading Aircraft	Heavy	B757	Heavy	B757
Trailing Aircraft	Heavy	Large/B757/Heavy	Small/Large/B757	Small
Sep. Minima, n mile	4	4	5	5

**Table 2 Wake separation minima at runway threshold when the trailing aircraft is small**

Leading Aircraft	Large	B757	Heavy
Sep. Minima, n mile	4	5	6

When certain required conditions are satisfied,<sup>17</sup> a reduced separation of 2.5 n mile is authorized. When two aircraft are on parallel dependent ILS approaches to runways with a center-line separation of at least 2500 ft but no more than 4300 ft, a minimum of 1.5 n mile is required. In the case of an arrival trailing a departure, a minimum of 2 n mile or 1000 ft must be maintained between the aircraft if the separation will increase to a minimum of 3 n mile within one minute after the takeoff. Between a VFR (Visual Flight Rules) aircraft and an IFR (Instrument Flight Rules) aircraft, the general separation minima are reduced to 1.5 n mile and 500 ft. If two aircraft are on diverging courses,<sup>17</sup> or if they are successive departing aircraft separated by more than 1 n mile,<sup>17</sup> or if both aircraft are established on their independent final approach courses, no separation minima are required.

## B. Prediction of Trajectories

A single flight trajectory based on the flight intent information available for each aircraft is used to predict aircraft position and thus the separation between a pair of aircraft within the look-ahead time.

### 1. Flight-Intent Information

In Next Generation Air Transportation System (NextGen), accurate flight-intent information is expected to be available for trajectory predictions. However, the more limited flight-intent information available today can still improve conflict predictions significantly.

For arrival flights, the aircraft generally follow the same nominal paths that have some common flexibility in the TRACON. Past air traffic automation efforts have used these prescribed nominal TRACON paths from the arrival meter fixes down to the runways.<sup>18</sup> These paths are sometimes referred to as *nominal interior routes* (NIRs). The NIR for an aircraft is unique given the airspace configuration and the engine type, meter fix, airport, and assigned runway. A typical NIR is shown in Fig. 1, where the squares on the center line are waypoints. The last two waypoints in the final leg are the final approach fix (FAF) and runway threshold fix (RWY). Most arrival aircraft are observed to follow the NIRs except that a base extension or “trombone” is common for downwind approaches. The shaded region is a conformance region defined by a conformance threshold. An aircraft is in conformance or ontrack if its cross-track distance to the center of the NIR is within the conformance threshold. As seen in Ref. [14], the NIR provides useful specific details on the route of the aircraft and thus represents good horizontal flight intent for arrival aircraft in today's system.

For departure flights, the useful flight-intent information available today includes the RNAV (Area Navigation) departure routes as illustrated in Fig. 2,

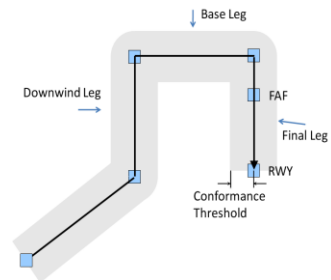

**Figure 1. A static nominal interior route**

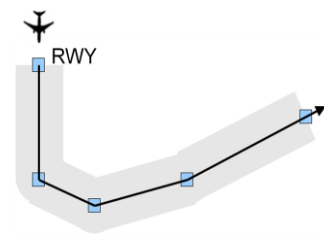

**Figure 2. An illustration of the RNAV departure route.**

where an aircraft departs from the runway and makes a left departure turn towards a departure meter fix. The squares indicate waypoints and the shaded region indicates again a conformance region within which the aircraft is considered ontrack. When available, RNAV departure routes are often closely adhered to. For overflights, the aircraft flight plan is usually sufficient. Other flight intent information includes the speed upper bound at initial departure waypoints, the speed lower bounds at final approach waypoints, as well as altitude restrictions at some common waypoints and level altitudes to be discussed in the next subsection.

## 2. Flight-Intent Trajectory

The flight-plan route, the RNAV departure route, and the nominal interior route are merged to form a flight-intent route, which is used to create the ground (horizontal) track of the aircraft with segments of straight lines and circular arcs. The underlying assumption for the trajectory prediction is that, whenever possible, an aircraft attempts to conform to its flight-intent route and other available intent information. Thus, when in conformance (on-track), it will stay in conformance; otherwise it will move along a straight line along its current course. However, the aircraft is assumed to be aware of its flight intent information in the sense that, when possible, it joins smoothly back with the next segment in its flight-intent route. This is summarized in the following general rules:

- 1) If the aircraft is ontrack, capture the next waypoint in the flight-intent route.
- 2) If the aircraft is offtrack, start with a straight line along its current course then, if possible, join the flight-intent route when it is intercepted; otherwise continue along the straight line.

Fig.3 shows an example of applying the above rules to predict the ground track of an initially offtrack aircraft. The aircraft starts off with a straight line track since it is offtrack. It then joins the flight-intent route along a circular-arc segment and becomes on track and moves forward.

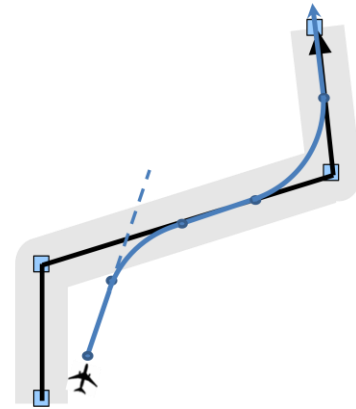

**Figure 3. Prediction of the ground track of an initially off-track aircraft.**

The radius of the circular-arc segments, assuming a coordinated turn, is estimated from the aircraft's current ground speed,  $V$ , and a bank angle,  $\phi_B$ , by  $r_c = V^2/g \tan \phi_B$ , where  $g$  is the acceleration of gravity and we use  $\phi_B = 30^\circ$ . Because base extensions are common and turns onto the final are constrained, special rules apply to downwind-to-base and base-to-final turns. The rules are summarized as follows, with the numerical values being based on engineering experience:

- 1) *Downwind-to-Base*: First, before a turn is detected, the aircraft is predicted to continue along its velocity vector. That is, a downwind-to-base turn will not commence until an actual turn of the aircraft has been detected. This rule is based on the observation that the base leg of the NIR is extended in most cases. The detection of a turn is defined as three consecutive course changes in the same direction (left or right). After a turn towards the base is detected, the actual turn radius is calculated based on the current rate of course change,  $\omega$ , and the current ground speed by  $r_a = V/\omega$ . If the current heading of the aircraft is more than 150 degrees from the final approach course, the aircraft is assumed to continue turning for 10 seconds or about two radar update cycles with the current actual turn radius,  $r_a$ , and then continue along a straight-line projection at the end of the turn. If the current course of the aircraft is within 150 degrees of the final approach course, the aircraft is assumed to continue turning with radius,  $r_a$ , to a course perpendicular to the final approach course. If the turn is not possible because  $r_a$  is too large, the coordinated turn radius,  $r_c$ , is tried. If the turn is still not possible, a straight line is used.
- 2) *Base-to-Final*: An aircraft approaching the final approach course with some angle is generally assumed to turn and start to intercept the final approach course at some minimum perpendicular distance,  $d$ , see Fig. 4 for a typical turn scenario. Based on visual inspection

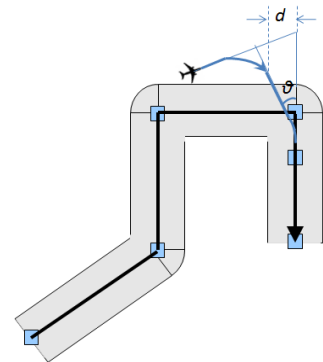
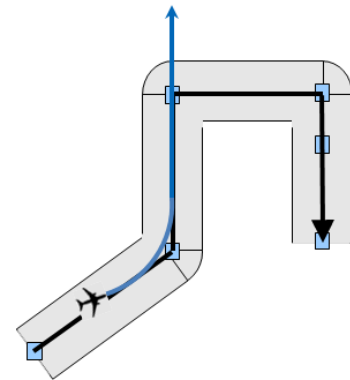

**Figure 4. Prediction of the ground track of an aircraft making a base turn and a typical intercept of the final approach course**

of many actual trajectories, we take  $d = 1$  n mile. Circular arcs and straight lines are used to construct the trajectories of interception. An interception angle,  $\theta = 30^\circ$  before the final approach fix is assumed. If an aircraft is already closer than 1 n mile to the final approach course, it is assumed to turn and intercept right away. If it is not possible to turn on to the final with one circular arc, it may overshoot and intercept the final with two turns or two circular arcs.<sup>19</sup>

Figure 5 shows an example prediction of an on-track aircraft turning into the downwind leg and continuing along a straight line without making a base turn because the aircraft is not predicted to make the base turn until it has been detected to be turning.

Once the ground track is predicted, a ground speed profile based on current ground speed and acceleration is generated for the aircraft to fly along the track. Our experience from comparing the trajectory predictions with the actual ground tracks of aircraft in the TRACON suggests that the ground speed changes significantly enough that it is necessary to model the acceleration. However, since the actual duration of deceleration of an aircraft is not known, the rate of the deceleration may be so large that the aircraft may be predicted to reduce its speed unrealistically to zero within the look-ahead period. Thus, a lower bound for the ground speed is necessary, especially during base leg and final approach phases. Similarly, the acceleration of a departing flight may be so large that an upper bound on the ground speed needs to be imposed. In this paper, ground speed lower bounds near the final approach and runway threshold fixes are imposed, and an upper bound is imposed on certain departure flights. Other bounds may be added in the future. When a ground speed bound is imposed, the aircraft is projected to fly at constant speed once the bound is reached.

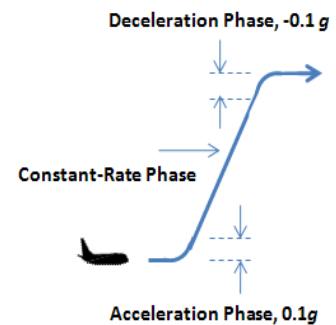

**Figure 5. Prediction of the ground track of an on-track aircraft turning into a downwind leg.**

The lower bound on the ground speed near the final approach fix is set at 160 knots. The bound at the runway threshold is 130, 115, or 95 knots depending on whether the engine type of the aircraft is jet, turboprop, or piston, respectively. The ground speed upper bound for departure flights is 260 knots for flights below 6500 ft. These numbers are based on observations of a large set of flight data. The results are not sensitive to the precise values. Given the current ground speed, the length of the predicted ground track, and the speed bound, a required acceleration may be calculated. In the case of a deceleration, if the magnitude of the required deceleration is larger than the current measured value, the required value will be used. Otherwise, current ground deceleration is used. Note that whereas wind effects are not explicitly taken into account, they are implicitly considered through modeling the ground acceleration.

The motion of an aircraft in the vertical direction is described by a vertical or altitude profile. The altitude profiles for climb or descent is modeled in three phases: an initial acceleration phase, a constant-rate phase, and a final deceleration phase. A vertical constant acceleration of magnitude  $0.1g$ , where  $g$  is the acceleration of gravity, is assumed for the initial and final phases. With this acceleration, it takes about 10 seconds for an aircraft to increase its climb rate by 2000 fpm. Fig. 6 illustrates the model of a three-phase climb. The following rules are used to determine the phase of a flight:

- 1) When the vertical distance to the cleared altitude is more than 200ft, and its climb or descent rate is more than 500 fpm, it is in the constant-rate phase.
- 2) When the distance is more than 200 ft and the climb or descent rate is less than 500 fpm, it is in the acceleration phase. (It is not in a deceleration phase since the speed would have to be larger for a stopping distance of 200 ft if the deceleration is  $0.1g$ .)
- 3) Otherwise the aircraft is in the deceleration phase.



**Figure 6. The three-phase climb of an aircraft**

Note that the numbers above are adjustable, but they appear reasonable when the predicted trajectory profiles are compared with many actual trajectories. The conflict prediction results are not sensitive to the precise values. If an aircraft is in the constant-rate phase, its constant vertical rate is given by its current vertical rate. If an aircraft is in the initial acceleration phase, its vertical speed at the constant-rate phase is obtained by looking up the nominal climb or descent rate in the Base of Aircraft Data (BADA) from Eurocontrol.<sup>20</sup>

Most altitude clearances are entered into the Host computer at each Air Route Traffic Control Center (ARTCC or Center). This is not the case in TRACON, where the altitude clearances usually are only communicated to the pilots by voice. In the future, such cleared altitudes may be entered into the system, in which case the clearances would become available intent data for use in predicting the trajectory. HITL experiments show that participating controllers are willing to enter the altitudes when the traffic is not too busy, especially when they see the benefits of entering them.<sup>15</sup> As in Ref. [14], for recorded real-world data, we extract the location and duration of level segments from the recorded data file of aircraft tracks and use them to generate simulated entry of altitude clearances. The resulting cleared altitudes are referred to as Inferred Altitude Clearances (IACs). Ref.[14] shows that IACs reduce the number of false alerts significantly.

### C. Prediction of Conflicts

Conflict predictions are based on the predicted trajectories. Inaccuracy in the predicted trajectories translates into inaccuracy in the prediction of conflicts. A given single definitive predicted trajectory may deviate significantly from the actual trajectory, but the next prediction is independent and can become quite accurate. Overall, the number of false alerts is reduced when multi-trajectory predictions are used, and the price to pay is somewhat reduced average alert lead time.

#### 1. Severity of an Impending Conflict

A good conflict detection tool should provide adequate alert lead time to the controller with minimal false alerts. Proper filtering of impending conflicts based on their severity would help to reduce false alerts. Furthermore, while controllers are not responsible for separation when aircraft are making visual approaches, moral responsibility makes them still want to be alerted when dangerous situations develop.

We define severities based on the concept of separation conformance categorization defined by FAA Order JO7210.56C<sup>16</sup> for classifying operational errors. Four classes of operational errors, A, B, C, and PE (Proximity Event), known as Separation Conformance Category (SCC), are defined as shown in Fig. 7 for non-wake separations. The vertical separation retained is defined by  $V_r = h/h_{std}$  where  $h$  is the aircraft vertical separation and  $h_{std}$  is the standard vertical separation. The horizontal separation retained is similarly defined by  $H_r = r/r_{std}$  where  $r$  is the horizontal separation and  $r_{std}$  is the standard horizontal separation. Defining a conformance separation  $s = \sqrt{V_r^2 + H_r^2}$ , we have classes A and B operational errors correspond to the intervals  $s < 34\%$  and  $34\% < s < 75\%$  respectively, while class C operational errors correspond to  $s > 75\%$  and  $V_r < 90\%$  or  $H_r < 90\%$  and class PE errors correspond to either  $V_r > 90\%$  or  $H_r > 90\%$ . Thus, the smaller the conformance separation, the more severe is the conflict. So the conformance separation in effect is a continuous measure of the severity of a conflict. For wake separations, only the horizontal separation is used and there are only A, B, and C classes, corresponding to the intervals  $H_r \leq 70\%$ ,  $70\% < H_r \leq 85\%$ , and  $85\% < H_r < 100\%$  respectively.

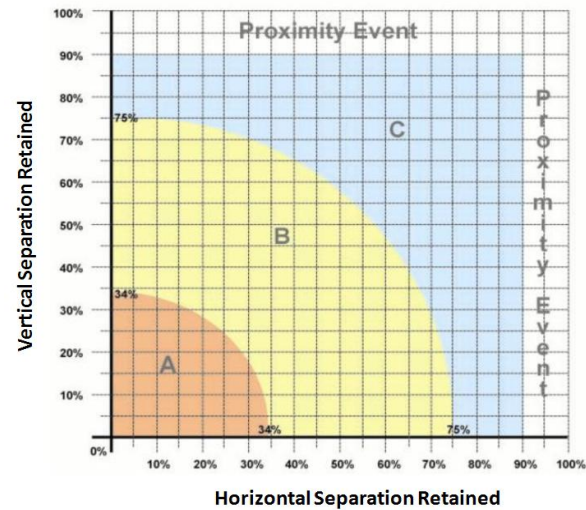

**Figure 7. Categorization of operational errors in A, B, C, and PE categories for non-wake separations.**

The time to the predicted conflict should be factored into the severity as well. Thus we define three discrete severity levels, high, medium, and low, as shown in Table 3. This is based on the time to and the SCC at the Closest

Point of Approach (CPA). Here the CPA is measured by the conformance separation so that it corresponds to the point of smallest conformance separation, or maximum conflict severity per the continuous severity measure. Thus, an impending conflict is of high severity if the time to the CPA is less than 40 seconds and the SCC at the CPA is either A or B.

**Table 3 Definition of the severity of an impending loss of separation**

Time to CPA, $t$ (seconds)	$t < 40$	$t < 40$	$40 < t < 70$	$t > 70$	$40 < t < 70$	$t > 70$
SCC at CPA	A or B	C or PE	A, B, or C	A or B	PE	C
<b>Severity</b>	<b>High</b>		<b>Medium</b>		<b>Low</b>	

## 2. Conflict-Prediction Options

To effectively reduce false alerts while avoiding late alerts, we explore three options for conflict predictions in this paper. These are the high, medium, and low severity options, corresponding to the onset severity of a predicted loss of separation. Thus, in the high severity option, conflict prediction is not made for a potential conflict situation until the severity of the impending conflict is high. Similarly a prediction is not made until the severity of the conflict is medium in the medium severity option and a prediction is made as soon as the severity becomes low in the low severity option. In any given option, an impending conflict in subsequent radar update cycles will continue to be predicted as a conflict even if the severity has become lower. A loss of separation is cleared when there are no more predictions of conflict of any severity for at least 30 seconds.

As usual, to guard against outlying data points or noisy track data, some heuristic methods are used to filter potential false alerts. We define our filtering rules assuming a 4.8 second TRACON radar track update cycle. Table 4 shows the filtering rules based on the time to the predicted first LOS and the number of consecutive predictions.

**Table 4 Filtering rules for conflict predictions**

Time to LOS $t$ (seconds)	$t \leq 30$	$30 < t \leq 60$	$60 < t \leq 90$	$t > 90$
No. of Consecutive Predictions	2	3	4	5

These rules are in addition to all conflict prediction options. An exception to these rules is that an impending LOS occurs within the past 25 seconds for the aircraft pair. Thus, a prediction of LOS for an aircraft pair with a time to the predicted LOS within 30 and 60 seconds will be ignored unless it was also predicted in the previous two radar update cycles or an impending LOS between the pair was predicted within the past 25 seconds. Note that this is stronger filtering than Ref. [14] to reduce false alerts of short duration. As a result a smaller alert lead time is expected. Less noisy radar data and more accurate intent information will allow loosening of these filtering rules.

A rule similar to the standard altitude rounding rule used in the Host computer at each Center is also adopted here. That is, any aircraft flying nominally level within 100 ft of its cleared altitude is considered to be exactly at its cleared altitude for the purposes of separation requirements. Furthermore, the first or second radar updates are excluded as the course is usually not accurate yet.

In general, the predicted states of a pair of aircraft at some look-ahead time are used to determine whether a loss of separation shall be predicted. The situation is more complicated when wake turbulence is involved, because the track history is required to determine if the trailing aircraft is operating directly behind (within 2500 ft of the flight path of) the leading aircraft. Thus, a 3-minute track history of each aircraft is kept. To check if wake separation applies to a pair of in-trail aircraft, the cross-track position of the trailing aircraft with respect to the track history of the leading aircraft must first be located. Then, if the altitude of the trailing aircraft is within 1000 ft below that of the leading aircraft at the perpendicular cross-track position, wake separation rules apply.

## III. Experimental Setup and Data

A prototype Terminal TSAFE system (T-TSAFE) has been developed<sup>13,14</sup> that sets up a framework for incorporating different conflict detection and resolution algorithms. The input to the system is an archived data file containing TRACON radar tracking data, Mode C barometric altitude data, flight-plan route data, and altitude amendments. These input data are used in the conflict detection algorithms to generate trajectories and detect

potential conflicts. Aircraft trajectories and conflict information are then saved and stored as XML files for post analysis.

T-TSAFE has also been incorporated seamlessly with the Multi-Aircraft Control System (MACS) and used in Human-In-The-Loop (HITL) experiments.<sup>15</sup> MACS provides a simulation framework to interface with controllers. In HITL experiments, many realistic scenarios were created to fly aircraft within the Southern California TRACON (SCT) with participating controllers directing arrival aircraft in ILS approaches to the finals. The HITL data is reasonably high-fidelity and has the additional benefit of including records of the controller or pilot intervention.

Conflict Alert in Terminal Airspace provides baseline numbers for comparison with T-TSAFE. CA has a false alert rate of about 80% and negative average alert lead time before loss of separation as its separation thresholds are much smaller than the separation standards. Analysis of the operational error reports also indicates that 90% of the time the controller did not act or acted after losses of separation had already occurred.<sup>14</sup> Furthermore CA produces too many alerts, especially Mode-C Intruder alerts where one of the aircraft has unknown call-sign. As a result, controllers have become desensitized to CA. A viable conflict alerting algorithm must do a much better job than CA.

Analysis of the aircraft trajectories and conflict information with T-TSAFE allows determination of the average alert lead time, false-alert rate, as well as total number of alerts as in Ref. [14]. Three complementary sets of traffic data are used analyze the severity-based conflict detection algorithm discussed in section II.

The first, operational-error data set consists of archived data files of aircraft pairs in 70 operational error cases from Dallas-Fort Worth (DFW) TRACON during the period between January 2007 and April 2009. These are the same data used and described in Ref. [14]. This set of data contains known losses of separation and can thus be used to measure average alert lead time<sup>14</sup> and to perform regression tests to verify the integrity of the algorithm whenever modifications are done.

The second, HITL data set consists of recorded files from 12 runs of the HITL experiments. Each run is about 40 minutes and contains realistic flights of ILS approaches directed by participating controllers with known intervention by controllers or pilots. While the participating controllers were good at avoiding potential LOSs, many conflicts were produced from intentional miscommunications, pilot errors, or simulation artifacts. In addition to being able to determine average alert lead time from the losses of separation, we can also determine the false alerts more objectively by checking if there is any intervention within a time window from 20 seconds before the first prediction of LOS to 10 seconds after the last prediction.

The third, mixed-operation data set consists of an 8-hour recorded data file with mixed operations of ILS and visual approaches to the finals. Because pilots are responsible for separation when the aircraft are cleared for visual approaches, most of the losses of separation detected by the algorithm are likely to be unreal as the separations are intentionally violated. However, pretending all approaches to be ILS so that the standard separation criteria apply allow a direct comparison with the recorded alert data from the actual Conflict Alert in the field. While the comparisons may not be on an equal footing, as the two systems have vastly different aircraft separation thresholds and look-ahead times, the results will shed light on the improvement of T-TSAFE over CA.

## IV. Results

In this section, results on the alert cumulative distributions, alert lead time, or alert rates for the three data sets and the three severity options of conflict detection are presented. Comparison with the alerts from the real Conflict Alert is provided as well.

### A. Operational Errors Data

A regression test against the operational-error data set from 70 operational error cases assures that the trajectory and conflict prediction algorithms can predict all the losses of separation expected for the operational errors. The alert cumulative distribution as a function of the alert time measured from the first LOS is presented in Fig. 8 for all three alerting options. The cumulative probability measures the percentage of the 71 LOS alerts (one of the operational errors involves three aircraft in two conflicts) that have an alert time larger than some given value. The probability of 1 on the zero-time column for the low and medium severity options indicates that all 71 LOSs were predicted. On the other hand, when the high-severity option was used, only 54% of the total LOSs or 38 LOSs were



predicted. This result is expected as the severity of some losses of separation never become high because they belong to class C or PE operational errors. As seen from the figure, the percentages of alerts with an alert lead time more than 30 seconds for the low and medium options are about 52% and 41%. This is reduced as compared with Ref. [14] because a stronger filtering is used here.

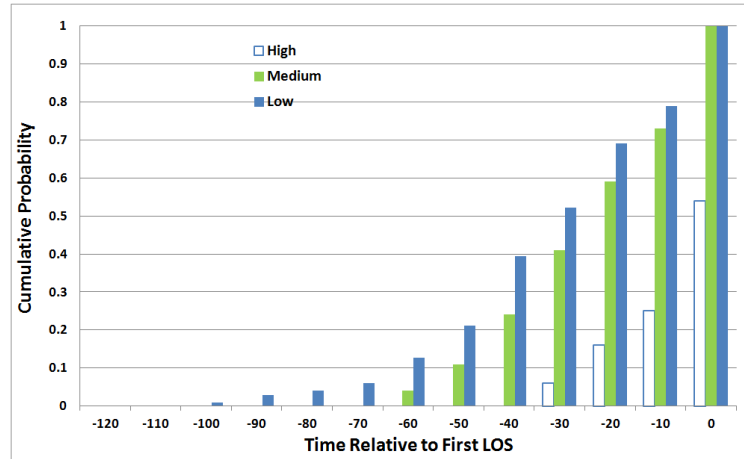

Figure 8. The cumulative distribution function of alerts as a function of alert time.

The average alert lead times for all three severity options were measured with two different look-ahead times of 120 and 100 seconds. The result is as shown in Fig. 9. As is seen, the alert lead times for the two look-ahead times are the same within errors. This is expected because the look-ahead time is much larger than the average alert lead time. However the average alert lead time changes noticeably for different severity options. The low-severity prediction option yields an average alert lead time of 33 seconds, the medium option 26 seconds, and the high option only 12 seconds. The average alert lead time for the high option drops since many medium-severity alerts with large alert lead times are removed and those with zero alert lead times remain.

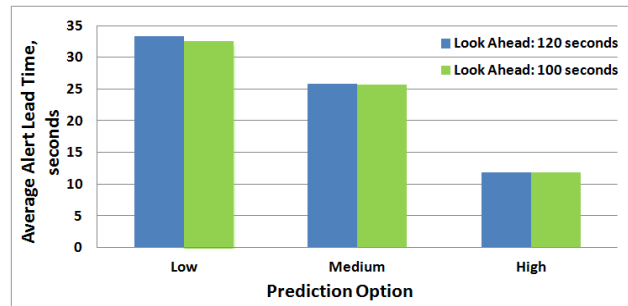

Figure 9. Average alert lead time measured from the data set of operational error cases for two look-ahead times.

The average alert lead time also depends significantly on the cases that have zero alert lead time. There are many situations in which it is impossible for T-TSAFE or any algorithm to predict a LOS with any lead time<sup>14</sup> unless additional intent information is provided. For example, if two level-flight aircraft with 1000 ft vertical separation have lost their horizontal separation minimum and are horizontally converging, they would immediately be in conflict if the upper aircraft starts to descend due to some operational error. Nevertheless, if the controller enters the clearance altitude in a T-TSAFE system before asking the pilot to descend, the conflict may be avoided since T-TSAFE could issue an alert as soon as the clearance altitude is entered. If the cases of zero alert lead time were excluded, the average alert lead time would be much larger. In a TRACON, an average alert lead time of 20 to 25 seconds is considered sufficient based on controller feedback. Thus, even the medium severity option can be used when the flight intent information is inadequate. As seen from the criteria discussed earlier, the low severity alerts may not be of much interest to controllers although it could provide early alerts to controllers before more serious conditions develop.

## B. HITL Data

With the HITL data set, where controller intervention information is available and the aircraft are expected to perform ILS approaches so that the separation minima are strictly enforced, the false alert rate can be measured more objectively. Fig. 10 shows the LOS alerts, valid non-LOS alerts, and false alerts for the three severity-based prediction options averaged over all 12 runs of data in the set. Here LOS alerts mean predictions which are actually followed by actual LOSs. Valid non-LOS alerts correspond to predictions that are not followed by actual LOSs but there are one or more controller or pilot intervention actions during the intervening period between the time 20 seconds before the first prediction and the time 10 seconds after the last prediction. False alerts are predictions that are not followed by LOSs and there is no controller or pilot intervention during the intervening period.

The relatively large number of LOS alerts is due to factors<sup>15</sup> such as intentional creation, simulation artifacts, as well as non-separation standards used when VFR flights are involved. Losses of separation were sometimes intentionally created to observe the separation rules or collect data. Note the VFR flights were introduced in non-class B airspace so technically no separation criteria apply. However, participating controllers wanted to get alerts so a horizontal separation minimum of 1.5 n miles and a vertical minimum of 500 ft were used in the experiment. The feedback from the controllers was that the alerts needed to be earlier. Thus, the same separation minima are used in this research when both the VFR and IFR flights are level, but the vertical minimum is increased to 1000 ft if one or both aircraft are climbing or descending. To provide even earlier alerts, we may need to increase the horizontal minimum to 2 n miles in the future when the flights are not level. As can be seen from Fig. 10, the false alert rate is less than 10% of the total number of alerts even for the low-severity prediction option. This agrees with previous analysis of real world data of visual approaches,<sup>14</sup> where similar false-alert rate was obtained.

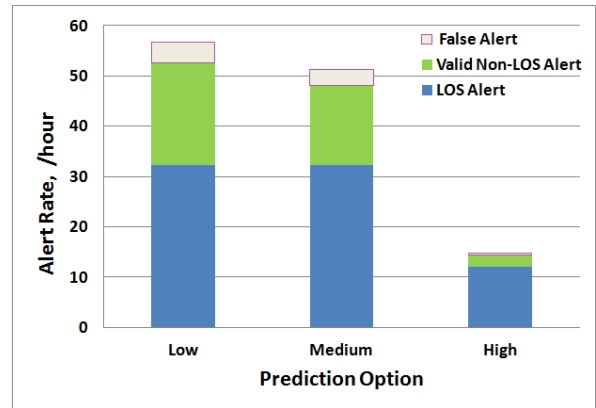
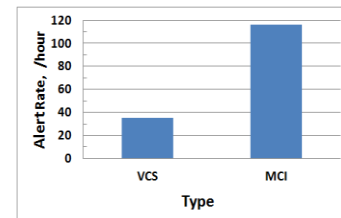

**Figure 10. Alerts per hour for different severity prediction options**

Notice that the number of LOS alerts is the same in the low and medium alerting options. This is expected because all the LOS alerts that show up in the low option should show up in the medium option as the time to LOS decreases. Going from the low to the medium option, the number of valid non-LOS alerts decreases by about 20% and so does the number of false alerts. The high option reduces both the LOS and non-LOS alerts significantly by the adoption of separation thresholds that are about 75% of the standard criteria.

### C. Mixed Operations Data and Conflict Alert

The mixed-operation data set consists of real-world traffic data at SCT from 15:00 to 23:00 Zulu on July 21, 2011. The weather conditions during the time window suggest mixed visual and ILS approaches might have been performed. The alert data from the actual Conflict Alert in the field for this data set was provided by the FAA. Fig. 11 shows the average CA alerts per hour for this data set. As is seen, the Mode C Intruder (MCI) alerts, which involve an IFR flight and a MCI which is a VFR with unknown call-sign, outnumber the Valid-Call-Sign (VCS) alerts, in where both aircraft have valid call-signs. The MCI alerts are about 75% the total CA alerts.



**Figure 11. Alerts per hour for the actual Conflict Alert.**

The traffic data for IFR flights corresponding to the above mixed-operation data set were archived at NASA, so the predictions of T-TSAFE and CA for flights with valid call-signs can be compared. After adding inferred altitude clearances into the recorded data file as altitude-amendment intent information, T-TSAFE alerts were generated for all three severity options of prediction with a look-ahead time of 100 seconds. A comparison of the alerts per hour between T-TSAFE and CA alerts is shown in Fig. 12. The alerts have been separated in terms of LOS and non-LOS T-TSAFE alerts. The overlap between T-TSAFE low-severity-option and CA alerts is also shown, indicating only about 13% of T-TSAFE alerts under the low severity options are alerted by CA. Taking into account the earlier estimation that about 10% of T-TSAFE alerts are false, we can conclude that about 80% of CA alerts with valid call-signs are false. This agrees with the analysis of Friedman-Berg et al.<sup>2</sup>

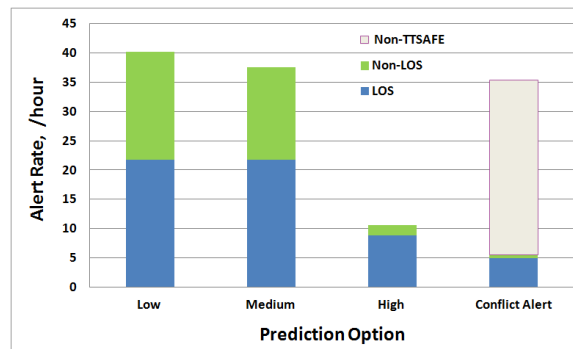

**Figure 12. Alerts per hour for the three predictions options of T-TSAFE and for Conflict Alert.**

Notice that the total number of T-TSAFE alerts for the low- or medium-severity prediction options is comparable to that of CA alerts. This number appears large even though it indicates significant improvement over CA considering its large look-ahead time and much larger separation thresholds. The contributing factors include visual approaches where the separation criteria are intentionally violated and unincorporated RNAV (Area Navigation) departure routes for the small airports other than Los Angeles International Airport. In practice, alerts on aircraft making visual approaches may be suppressed without affecting alerts on other ILS approach flights.

To see how visual approaches may affect the results, T-TSAFE was applied to the same recorded data with the assumption that one or both aircraft in a conflict pair make visual approaches if the two aircraft are on different runways. The aircraft involved then have no required separation minima. To provide some safety protection, if one of the aircraft overshoots its localizer, the standard separation criteria are still applied. Figure 13 shows alerts per hour for the three severity prediction options under the visual approach assumption. Comparison of Figs. 12 and 13 shows a noticeable reduction in the total number of alerts. In particular, a high-severity option together with the overshoot alerting for aircraft on different runways can be adopted when visual approaches are conducted. This way the number of alerts will not be overwhelming to the controllers.

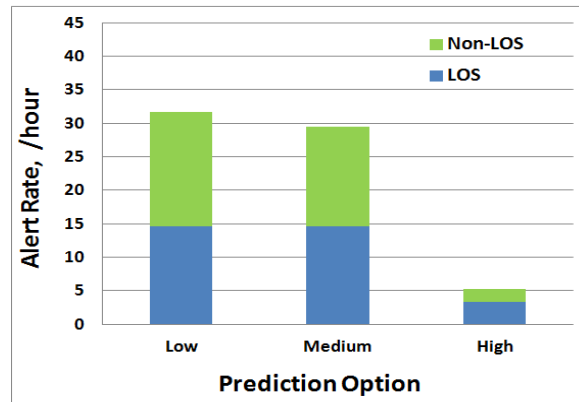

Figure 13. Alerts per hour for the three predictions options with the visual approach assumption.

## V. Conclusions

A severity-based conflict detection algorithm, enhanced from Ref. [14], has been studied in this paper. The severity of a conflict (impending loss of separation (LOS)) has been defined in terms of the predicted time and distance to the closest point of separation between the two aircraft measured relative to the standard separation criteria. This is based on the FAA separation conformance category for classification of operational errors. A single-trajectory approach to conflict detection, in which available flight intent information is used in the trajectory prediction, attempts to strike a balance between the average alert lead time and the false alert rate. When the flight intent available is scarce and inaccurate as is today, low severity conflicts may be filtered out and still retain an acceptable average alert lead time. When in areas far from the airport where traffic is less busy and longer alert lead time is desired, low-severity alerts should be retained. When aircraft performing visual approaches are involved, alerts on high severity conflicts may still be generated even though the controller is no longer responsible for separation. This will provide a safer operation without increasing much controller workload while satisfying the controller's moral responsibility to monitor separation.

The algorithm has been analyzed with three complementary sets of aircraft track data, and a comparison has been made with the real Conflict Alert in the field. The first set, which involves real-world data with documented LOSs due to operational errors, allows determination of average alert lead time as well as regression testing of the algorithm. The second set, which involves realistic data from human-in-the-loop experiments with aircraft only performing Instrument Landing System (ILS) approaches and with available records of intervention from controllers or pilots, allows more objective determination of false alert rate. The third set, which involves real-world data with aircraft performing mixed operations of visual and ILS approaches, has CA alerts available for comparison. Compared to CA, the algorithm produces a much smaller false alert rate (10% vs 80%) although it uses a much larger safety buffer (standard separation criteria vs dangerous proximity). Furthermore, the algorithm generally provides sufficient alert lead time as well, whereas CA has little alert lead time since the aircraft are already in dangerous proximity of each other by the time the conflict is alerted.

Whereas false alerts and average alert lead time are at manageable levels, the total number of alerts the algorithm generates appears large and is comparable to Conflict Alert. Although in some cases this may be attributed to factors such as visual approaches and unincorporated flight intent information such as RNAV (Area Navigation) departure routes, more extensive study is needed. Furthermore, the analysis with the real-world traffic data of mixed

operations is affected significantly by the inferred altitude clearances. Effective inclusion of waypoint restrictions on altitudes may be used so that controllers only need to enter altitude clearances when resolving conflicts. Finally, how the algorithm handles Mode C Intruders is under investigation.

## References

- <sup>1</sup>“National Airspace System En Route Configuration Management Document, Host-A5f1.3: Computer Program Functional Specifications, Automatic Tracking”, Federal Aviation Administration, NAS-MD-321 2002.
- <sup>2</sup> Friedman-Berg F, Allendoerfer K., and Shantanu Pai, “Nuisance Alerts in Operational ATC Environments: Classification and Frequencies”, Proceedings of the human factors and ergonomics society, 2008.
- <sup>3</sup>Erzberger, H., “The Automated Airspace Concept”, Proceedings of the fourth USA/Europe Air Traffic Management R&D Seminar, Santa Fe, New Mexico, USA, December 3-7, 2001.
- <sup>4</sup>Erzberger, H. and Paielli, R.A., “Concept for Next Generation Air Traffic Control System”, Air Traffic Control Quarterly, vol. 10, no. 4, 2002, pp.355-378.
- <sup>5</sup>Erzberger, H., “Transforming the NAS: The Next Generation Air Traffic Control System”, NASA/TP-2004-212828, October 2004.
- <sup>6</sup>“Introduction to TCAS II Version 7”, Federal Aviation Administration, Washington D.C., Nov. 2000.
- <sup>7</sup>Erzberger, H., Davis, T.J., and Green, S.M., “Design of Center-TRACON Automation System”, AGARD Meeting on Machine Intelligence in Air Traffic Management, Research and Technology Organization, May 1993.
- <sup>8</sup>Paielli, R.A. and Erzberger, H., “Tactical Conflict Detection Methods for Reducing Operational Errors”, Air Traffic Control Quarterly, Vol. 13(1), 2005, pp 83-106.
- <sup>9</sup>Paielli, R.A. and Erzberger, H., “Analysis of False-Alert Rates for a Tactical Conflict Detection System”, AIAA Paper ATIO-05, Sept. 2005.
- <sup>10</sup>Paielli, R.A., Erzberger, H., Chiu, and Heere, K.R., “Tactical Conflict Alerting Aid for Air Traffic Controllers”, AIAA, Journal of Guidance, Control, and Dynamics, Vol.32, No.1, 2009, pp 184-193.
- <sup>11</sup>Erzberger, H. and Heere, K., “Algorithm and Operational Concept for Resolving Short Range Conflicts”, University of California, Santa Cruz. Paper No. 383, ICAS-08, Sept. 2008.
- <sup>12</sup>Paielli, R.A., “Tactical Conflict Resolution using Vertical Maneuvers in Enroute Airspace”, AIAA, Journal of Aircraft, Vol.45, No.6, 2008, pp 2111-2119.
- <sup>13</sup>Tang, H., Denery, D., Erzberger, H., and Paielli, R.A., “Tactical Separation Algorithms and Their Interaction with Collision Avoidance Systems”, AIAA, GNC conference, AIAA-2008-6973, August, 2008.
- <sup>14</sup>Tang, H., Robinson, J.E., and Denery, D.G., “Tactical Conflict Detection in Terminal Airspace”, AIAA, Journal of Guidance, Control, and Dynamics, Vol.34, No.2, 2011, pp 403-413.
- <sup>15</sup>Verma, S.A., Tang, H., Kozon, T.E., Ballinger, D.S., and Farrahi, A.H., “Initial Human-In-The-Loop Evaluation of a Tactical Conflict Detection Tool in the Terminal Area”, 4<sup>th</sup> International Conference on Applied Human Factors and Ergonomics, San Francisco, July 2012.
- <sup>16</sup>Air Traffic Quality Assurance FAA Order JO 7210.56C, Federal Aviation Administration, Washington, DC. Aug. 2002. (Published online at <http://www.faa.gov>).
- <sup>17</sup>Air Traffic Control FAA Order JO 7110.65S, Federal Aviation Administration, Washington, DC. Feb. 2008. (Published online at <http://www.faa.gov>).
- <sup>18</sup>Swenson, H. N., Hoang, T., Engelland, S., Vincent, D., Sanders, T., Sanford, B., and Heere, K., "Design and Operational Evaluation of the Traffic Management Advisor at the Fort Worth Air Route Traffic Control Center," 1st USA/Europe Air Traffic Management R&D Seminar, Saclay, France, June 1997.
- <sup>19</sup>Erzberger, H. and Lee, H.Q., “Terminal-Area Guidance Algorithms for Automated Air-Traffic Control”, NASA/TN-D-6773, April 1972.
- <sup>20</sup>“User Manual for the Base of Aircraft Data (BADA)”, Revision 3.6, EEC Note No. 10/04, ACE-C-E2, Eurocontrol Experimental Centre, 4 July 2004.