

Design and Evaluation of an Air Traffic Control Final Approach Spacing Tool

T. J. Davis, H. Erzberger, S. M. Green, W. Nedell

Reprinted from

Journal of Guidance, Control, and Dynamics

Volume 14, Number 4, July-August 1991, Pages 848-854



A publication of the
American Institute of Aeronautics and Astronautics, Inc.
The Aerospace Center, 370 L'Enfant Promenade, SW
Washington, DC 20024-2518

Design and Evaluation of an Air Traffic Control Final Approach Spacing Tool

Thomas J. Davis,* Heinz Erzberger,† and Steven M. Green*
NASA Ames Research Center, Moffett Field, California 94035
and
William Nedell‡
San Jose State University, San Jose, California 95106

This paper describes the design and simulator evaluation of an automation tool for assisting terminal radar approach controllers in sequencing and spacing traffic onto the final approach course. The automation tool, referred to as the Final Approach Spacing Tool (FAST), displays speed and heading advisories for arriving aircraft as well as sequencing information on the controller's radar display. The main functional elements of FAST are a scheduler that schedules and sequences the traffic, a four-dimensional trajectory synthesizer that generates the advisories, and a graphical interface that displays the information to the controller. FAST has been implemented on a high-performance workstation. It can be operated as a stand-alone in the terminal radar approach control facility or as an element of a system integrated with automation tools in the air route traffic control center. FAST was evaluated by experienced air traffic controllers in a real-time air traffic control simulation. Simulation results summarized in the paper show that the automation tools significantly reduced controller work load and demonstrated a potential for an increase in landing rate.

Introduction

INCREASING delays and airspace congestion at major airports are among the most critical problems facing the air transportation system. It is widely recognized that the introduction of advanced automation techniques in air traffic control (ATC) offer a high potential for alleviating these problems. This paper describes the design of an automation system for assisting controllers in the management of arrival traffic in the terminal area.

The first innovative design of an automation system for terminal area ATC was developed in the late 1960s.¹ This system, the progenitor of all automation aids, provided speed and heading advisories to help controllers increase spacing accuracy on final approach. Although traffic tests of the system showed an increase in landing rate, controllers found that their work load was increased and they rejected the system. A retrospective examination of the concept suggests that the design was sound but its effectiveness was limited by the technology of the period, especially its lack of an adequate controller interface. More recently, an automation system that generates arrival schedules and advises controllers on the sequence was developed and tested with considerable success.² This system is currently being evaluated in a live air traffic environment.³ In addition, a recent fast time simulation study confirmed the potential for increasing landing rate with the assistance of automation aids.⁴

Recent research at NASA Ames Research Center has resulted in the design and laboratory implementation of an in-

tegrated Center/TRACON Automation System (CTAS) for the efficient control of arrival traffic. The elements comprising this system are the traffic management advisor (TMA) and the descent advisor (DA) to be used in air route traffic control centers (ARTCC or Center) and the Final Approach Spacing Tool (FAST) to be used in terminal radar approach control (TRACON or Terminal) facilities.^{5,6} The advisories generated by these tools assist controllers in handling aircraft arrivals starting at about 200 n.mi. (45 min) from the airport and continuing to the final approach fix. During the last two years, the three elements of this system have been evaluated by Center and TRACON controllers in several real-time simulations.

This paper begins with an overview of the CTAS tools (i.e., the TMA, DA, and FAST). Then the paper focuses on the design and evaluation of FAST, the main function of which is to provide speed and turn advisories that help controllers achieve an accurately spaced flow of traffic on final approach. The paper concludes with a description of results from a recent real-time simulation that evaluated the acceptability of FAST to TRACON controllers and its effect on landing rate.

Overview of Automation System Concept

The Center/TRACON Automation System consists of three sets of integrated tools, referred to as TMA, DA, and FAST. TMA is a tool for the Center whose primary function is to plan the most efficient landing times. The scheduling algorithms implemented in TMA generate landing sequences that minimize overall system delay. The TMA plans these times such that traffic approaching from different directions will merge on the final approach without conflicts and with optimal spacing. The principal function of the DA is to assist the Center controllers in implementing the arrival schedules generated by TMA. It provides descent speed profiles, top of descent points, and turn advisories that help controllers deliver aircraft at feeder gates (the entry point into the TRACON) at specified times. DA also provides conflict detection and resolution advisories, together with an interactive graphical interface. A detailed description of the TMA and DA is given in Ref. 5.

FAST provides tools to assist TRACON controllers in keeping aircraft on precise time controlled trajectories from the feeder gates to the final approach fix. Although primarily

Received April 27, 1990; revision received July 30, 1990; accepted for publication Aug. 6, 1990. Copyright © 1990 by the American Institute of Aeronautics and Astronautics, Inc. No copyright is asserted in the United States under Title 17, U.S. Code. The U.S. Government has a royalty-free license to exercise all rights under the the copyright claimed herein for Governmental purposes. All other rights are reserved by the copyright owner.

*Research Scientist, Aircraft Guidance and Navigation Branch, Mail Stop 210-9. Member AIAA.

†Assistant Chief, Aircraft Guidance and Navigation Branch, Mail Stop 210-9. Fellow AIAA.

‡Research Scientist, Department of Meteorology, One Washington Square, P.O. Box 760.

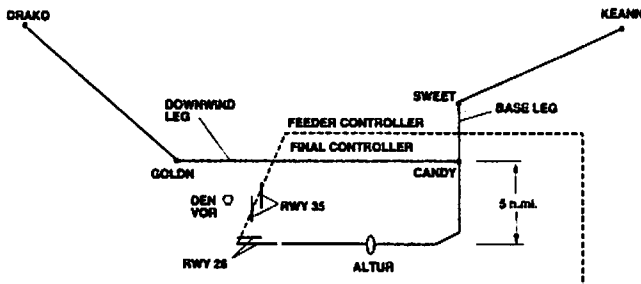

Fig. 1 Arrival procedure for Denver TRACON to runway 26L.

based on the same set of scheduling and four-dimensional trajectory algorithms as the Center TMA and DA, it also has several capabilities designed specifically to handle the unique problems occurring in the TRACON.

Terminal Controller Procedures for Managing Arrival Traffic

An understanding of controller procedures for managing arrival traffic provided important insight and motivation for designing FAST. Hence, these procedures are reviewed in preparation for describing the TRACON automation tools in the next section.

Typically, arrival traffic is handed off from the Center to the TRACON airspace at the feeder gates, which are about 30 n.mi. from the airport and 10,000–15,000 ft above ground level. Some airports utilize as many as four or five such gates or corner posts that approximately form a rectangle with the airport at the center.

Once the aircraft have been handed over to the TRACON, they are initially handled by a feeder controller. The feeder controller's task is to descend and slow the traffic into a single stream from each feeder gate while maintaining adequate (safe) spacing between aircraft. Typical spacing goals for the feeder controller depend heavily on traffic density but are usually 5 to 12 n.mi. A final controller then merges arrival traffic from the various feeder gate streams onto the final approach course using separations ranging from 3 to 6 n.mi. at the runway threshold depending on aircraft weight categories. Because aircraft are relatively close to each other in the TRACON and must be merged from separate arrival paths onto one single final approach path, the feeder and final controllers are kept extremely busy communicating with the aircraft and selecting which aircraft will be first, second, third, and so on.

Both feeder and final controllers attempt to keep aircraft on a fastest or shortest path to the runway. They often utilize speed changes, altitude changes, and path stretching to ensure proper spacing. If the arrival traffic rate is too high, controllers will begin slowing all traffic. This slowdown may not always be necessary for all aircraft in busy traffic periods and, in some cases, may actually create new problems and conflicts. Path stretching could involve extending or compressing the downwind leg of an approach or taking an aircraft out of its arrival stream and into a less dense arrival stream. Accurate control of interarrival spacing is further complicated by wind speed and direction changes.

Both feeder and final controllers must also merge "popup" (unexpected), tower en route (traffic arriving from an airport internal to the TRACON), and missed approach aircraft into one of the arrival streams. The controllers accomplish this by the previously mentioned method of speed control, path stretching, and searching for an open slot in an arrival stream in which to merge the aircraft.

In this paper, all procedures and simulations are based on Denver's TRACON for arrivals to Stapleton International Airport's Runway 26L (Rw 26L). Figure 1 shows the nominal routes in the northern half of the TRACON for arrival traffic to Rwy 26L and the airspace delegated to the feeder and final

controller. Aircraft arriving at the feeder gates, Drako and Keann, are navigating on an inbound radial to the Denver very-high-frequency omnidirectional range (VOR). As soon as an aircraft enters the TRACON, they are cleared to 11,000 ft. If the aircraft is arriving from Keann, it will be slowed to 210-kts indicated airspeed (IAS) before being turned to base and handed off to the final controller. Aircraft arriving from Drako are slowed to 210 kts at the turn to the downwind leg and just before handoff from the feeder to the final controller. After being handed off to the final controller and, in the case of Drako arrivals, after clearing the departure runways (35L and 35R) at 11,000 ft, the aircraft are descended to 8000 ft. As the aircraft are given a base turn clearance, they are slowed to 170 kts and a short time later are given a right turn clearance to 240 deg and cleared for the approach. Note that the Denver Stapleton International Airport field elevation for Rwy 26L is 5333 ft.

Most speed adjustment advisories (nominally 210-kts IAS) are issued at the point where aircraft are handed off to the final controller (Fig. 1). Path extension is usually given as an extension of the base leg turn. Path shortening procedures employed by controllers typically consist of directing the aircraft from the inbound Drako radial to a point on a shortened downwind leg and directing aircraft from the inbound Keann radial directly to a point on the final approach course.

Final Approach Spacing Tool

FAST consists of three major software elements: a scheduler, a four-dimensional trajectory generator, and a graphical advisory interface, each of which is briefly described in the following sections. These are followed by a brief discussion of compatibility issues between CTAS and flightpath management system (FMS) equipped aircraft.

Scheduler

The function of the scheduler incorporated in FAST is to generate optimally spaced landing times for arrival aircraft. These landing times are subsequently fed as input to the four-dimensional trajectory generator in FAST, which computes appropriate heading and speed advisories that help the controller keep the aircraft on time. Algorithmically, the scheduler in FAST is essentially identical to the one in the Center TMA. The primary difference between them involves the choice of the scheduling and freeze horizons. These time parameters determine when arrivals are initially assigned landing times and when the landing times are frozen. Appropriate values for these parameters were determined experimentally and are typically set at 11 and 8 min to touchdown, respectively.

The operation of the scheduler, described in Refs. 5 and 7 is briefly reviewed here. The primary inputs to the scheduler are periodically updated estimated times of arrival (ETA) for all aircraft that are being tracked by the terminal area radar systems. When the ETA of a new arrival first falls within the scheduling window, which is defined as the time interval between the scheduling and freeze horizons, the scheduler begins generating scheduled times of arrival (STAs). The scheduler first attempts to place a new arrival at a time identical to its ETA on the runway. If such a choice of STA creates a spacing violation with previously scheduled aircraft, the scheduler assigns the closest available time that meets the minimum allowed spacing distance on final approach. The minimum time separations used by the scheduler are derived from minimum separation distances specified by FAA regulations. The minimum spacing distances depend on the weight classes of the aircraft in the landing sequence and can be represented in a matrix of separation distances (n.mi.), as given in Table 1. As explained in Ref. 8, this matrix of distances is converted to a corresponding matrix of time separations by incorporating knowledge of final approach speeds. Furthermore, buffers on the order of 10–20 s are added to these minimum time separations in order to protect against unavoidable errors in the ability to control landing times using the FAST advisories.

Table 1 Separation distances

Leading aircraft type	Trailing Aircraft Type		
	Heavy	Large	Light
Heavy	4	5	6
Large	3	3	4
Light	3	3	3

The magnitude of the differences between the initial ETA and the STA generated by the scheduler depends both on the orderliness of the arrival stream and on the excess of the total arrival flow over the maximum landing rate. If the arrivals into the TRACON airspace are controlled by the DA and TMA, they should arrive at the gates with only small time errors and the flow rate will match the runway acceptance rate. In that case, the scheduler in FAST will make only minor changes in the STA originally calculated by the Center TMA. These changes will correct the small time error accumulated during the descent and the transition from the Center into the TRACON. Most of the time, therefore, the scheduler will be able to preserve the optimal landing sequence originally calculated by the Center TMA. For the case where aircraft do not comply with the Center DA clearances and arrive at the gates with large time errors, the scheduler in FAST will reorder the arrival sequence. The reordering is performed in a way that minimizes the overall delay in the TRACON by keeping as many arrival slots filled as possible and by maintaining most or all aircraft on a shortest path to the runway.

If the Center automation tools, DA and TMA, are not in operation, the flow into the TRACON during rush periods will be strongly bunched and may exceed the maximum runway acceptance rate for a period of time. Because of maneuver airspace restrictions and other factors, a TRACON scheduler has less freedom to optimize the arrival sequence than the Center scheduler and, therefore, cannot be as effective in reducing delays. However, the FAST scheduler is designed to handle such difficult flow conditions. It will generate landing sequences and STA that minimize delays subject to operational constraints. Under excess traffic load, the STA generated by the scheduler will absorb delays in the TRACON by holding or path stretching.

An important function built into the scheduler is the capability for handling unscheduled arrivals such as missed approaches and pop-up traffic. With these functions, the scheduler opens up a time slot where such aircraft can be reinserted into the arrival sequence. Under saturated traffic conditions the insertion of an extra slot will, inevitably, introduce delays for aircraft that follow the inserted aircraft. The rescheduling function assists the controller in finding a slot in the arrival sequence that will minimize disruption of the overall traffic flow.

Four-Dimensional Trajectory Generator

The FAST descent trajectory synthesis algorithm is a modified version of the Center DA algorithm. A detailed description of the algorithm is given in Ref. 9. Similar to the Center DA, it employs a second-order Runge-Kutta forward integration scheme to synthesize a path to the runway based on standard TRACON operations, aircraft state and type, and wind speed and direction.

Upon arrival into TRACON airspace, the FAST four-dimensional trajectory generator predicts the arrival time of an aircraft at the final approach fix (normally the outer marker) based on its current position, altitude, speed, and heading. The prediction is based on a set of standard arrival routes, airspeed deceleration schedules, and altitude profiles that conform to standard operations at a given TRACON. Next, the FAST four-dimensional trajectory generator computes a range of arrival times based on the aircraft speed envelope and allowable path extension. These predicted trajectories are updated every 5 s. If the STA and ETA are the same,

the aircraft is maintained on its present nominal path, altitude, and speed profile to the runway. If the ETA shows the aircraft to be early, the FAST four-dimensional trajectory generator will synthesize a descent trajectory that attempts to eliminate the time error by first decreasing the aircraft airspeed and then, if necessary, extending the path distance to the runway. If the ETA shows the aircraft to be late, the controller is advised to have the aircraft maintain higher speeds or shorten its path to the runway by utilizing the horizontal guidance modes that will be described next.

Construction of the horizontal route always begins at the current position and heading of the aircraft and terminates at the final approach fix. The current position need not be on a standard path to the final approach course. The controller may vector the aircraft anywhere in the TRACON arrival airspace, and a horizontal route will be synthesized based on either a route-intercept (RI) procedure or a waypoint capture (WC) procedure.

Route intercept operates in conjunction with a set of standard or nominal arrival routes converging on the final approach course to the runway. The routes comprising the nominal arrival path from the north to Rwy 26L at Denver's Stapleton International Airport are the final approach course extending 15 n.mi. beyond the outer marker (Altur), a base leg positioned 5.5 n.mi. from the outer marker and extending 15 n.mi. north from and perpendicular to the final approach course, and a downwind leg positioned 5 n.mi. north of and parallel to the final approach course (see Fig. 1). Each route has a corridor width of ± 0.5 n.mi. relative to its centerline.

As an aircraft enters the TRACON airspace from one of the feeder gates (Drako or Keann) the FAST trajectory synthesis algorithm puts the aircraft into a free-vector mode. In this mode, the algorithm seeks an interception of one of the defined route segments by extending the instantaneous course vector. From the first point of interception, the algorithm completes the path by following the nominal route to the final approach fix. After the aircraft has captured the downwind leg, the horizontal synthesis computes a new RI of the base leg. Similarly, once the aircraft has intercepted the base leg, a new RI of the final approach course is computed. The path to the runway is recomputed approximately every 5 s based on the current position and heading. This free-vector mode with RI logic allows the controller the freedom to vector aircraft anywhere in the arrival airspace and still maintain a highly accurate estimate of arrival time as long as the aircraft is heading for a standard route segment.

The horizontal path synthesized by the WC mode consists of an initial circular arc starting at the current position and course followed by a straight-line segment leading directly to a designated capture waypoint and ending with a circular arc turn intercepting the route containing the capture waypoint. The geometry of this construction is illustrated in Fig. 2. The algorithm determines the radius of the turn from the airspeed, wind speed, and maximum allowable bank angle. Furthermore, the direction of the turn toward the capture waypoint is chosen so that the total length of the path is minimized. In order to compensate for computational delays and to allow for controller response time, the algorithm also moves the start of the turn at each computational cycle at a distance equivalent to 10 s of flight time ahead of the current aircraft position. As in other trajectory synthesis modes, the predictive algorithm refreshes the WC profile in a 5-s cycle using updated aircraft state information. The WC mode can be manually selected by the controller for special situations such as missed approach guidance. It is also selected automatically by FAST at various times or if the RI mode fails to generate a four-dimensional trajectory under certain circumstances.

Graphical Advisory Interface

A sketch of the various elements of the graphical interface is given in Fig. 3. Similar to the Center DA, a vertical time line is used to display the current STA and ETA for all aircraft in, or

expected to arrive in, the TRACON airspace. In Fig. 3, the time line is shown on the right side of the display. The right side of the time line displays the current ETA and the left side of the time line displays the STA for each aircraft. The STAs are color-coded based on the direction from which the aircraft will arrive. This increases the speed with which the controller can correlate an aircraft's location on the time line with its location on the plan view display (PVD). If the STA and ETA are different during the aircraft's flight in the TRACON, FAST will provide speed advisories and heading vectors required for the aircraft to meet the STA. As the advisories are displayed, the ETA on the time line will adjust itself to reflect the effect of each update.

When FAST determines that a speed adjustment is necessary at a given point and the aircraft is within 5 n.mi. of that point, the advised IAS is displayed on the aircraft data tag below the ground speed in orange (210 kts for UAL234 in Fig. 3). The use of color on the tag alerts the controller that an advisory is pending. Having the advised speed on the tag allows the controller to maintain his concentration on the aircraft position. In addition, the point along the current predicted path where the speed adjustment should be issued is highlighted with an orange-shaded, circular marker to correlate with the orange speed advisory on the data tag. The 5-n.mi. advance notice and spatial display of the position where the speed adjustment should occur allows the controller to plan ahead for its issuance.

Another common technique used by TRACON controllers to delay or advance an aircraft is to either extend or compress the downwind leg of the approach path or vary the intercept point on the final approach course. Thus, when an aircraft arrives from the west to land on Rwy 26L and is within 5 n.mi. of its advised turn to base or turn to final, the data block is colored blue and a blue turn arc appears at the position where the instruction to turn should be issued. Once the aircraft has completed the base or final turn, the aircraft color reverts back to its normal green, and the turn arc for that aircraft disappears. Similarly, aircraft arriving from the east are color coded white for base and final turn advisories. The positions of the base and final turn advisories vary for each aircraft depending on its current time error relative to its STA and are displayed in the position that will eliminate the error. In Fig. 3, the controller is being advised where to turn COA557 to base and NWA305 to final.

In addition to its display on the time line, time error is also displayed below the altitude slot on the third line of each aircraft's data tag. The arrival time error, in seconds, is preceded either by an E for early or an L for late. Figure 3 shows that UAL234 is currently projected to be late at the final approach fix by 9 s, COA557 is projected to be early by 12 s, and NWA305 is projected to be early by 2 s. The advisories that will be issued to each aircraft should eliminate most or all of the current time errors. The controller may choose to use this time error mode alone or in combination with the speed vector and time line advisory modes to improve time control accuracy.

Interface to Flightpath Management Systems

An essential requirement for a ground-based automation system is designing it to be compatible with onboard FMS equipment. Onboard FMSs are becoming standard equipment in modern transport aircraft. In a broad sense, compatibility is inherent in the approach to ATC automation, as described in this paper. The landing times generated by the scheduler provides an input either to the controller advisory tools DA and FAST for time controlling the conventionally equipped aircraft or they can provide an input to FMS aircraft with time-control capability. For such aircraft, the controller need only issue the landing times by voice or they can be sent directly from the scheduler to the aircraft via the future data link. Thus, a single time clearance can take the place of a series of heading, speed, and altitude clearances, thereby reducing controller-pilot communications. This also increases the time control accuracy and contributes to increased landing rates.

Another aspect of compatibility concerns the various methods used to synthesize trajectories in the ground-based system and onboard systems. The method for trajectory synthesis incorporated in DA and FAST was originally developed for onboard FMS applications^{10,11} and was later adapted for use in ATC automation. In effect, DA and FAST provide the controller with FMS capability on the ground to handle unequipped aircraft. Many operational FMSs have also been designed on the basis of this synthesis method and therefore produce similar trajectories for similar conditions. If significant differences still occur and become a problem, the ground-based system can also be expanded to incorporate synthesis methods of different types of FMSs, analogous to the way it accounts for different aircraft models. Although in specific circumstances compatibility requirements can raise some subtle issues, there do not seem to be any insurmountable obstacles to overcome. A recent study examined several issues relating to mixing FMS-equipped aircraft with unequipped aircraft in a terminal area automation system.¹²

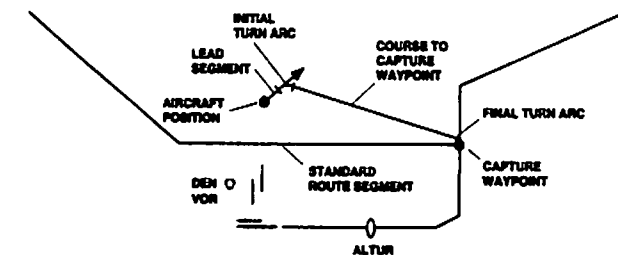

Fig. 2 Waypoint capture guidance.

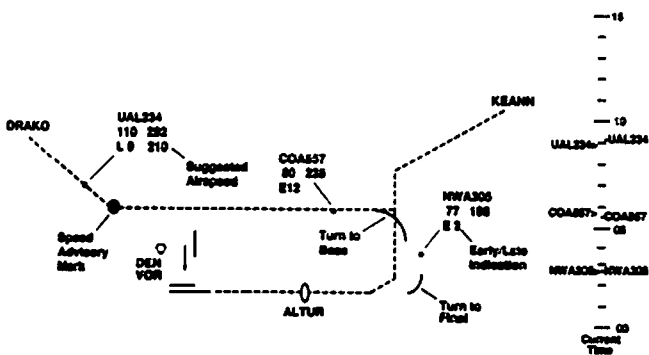

Fig. 3 Final approach spacing tool graphical advisories.

Simulation Description

A simulation evaluation of FAST, in conjunction with the TMA and DA, was conducted in January 1990. The objectives of the simulation were to 1) determine controller performance and runway capacity effects with and without automation tools, and 2) evaluate controller acceptance of the FAST concept.

A diagram of the various hardware and software components of the simulation is shown in Fig. 4. Included as one of the aircraft in the simulation was the Man-Vehicle Systems Research Facility (MVSRF) B727-200 full mission simulator. The 727 aircraft, which was piloted by active airline crews, executed up to four approaches from level flight cruise down to the runway in each simulation session. All other aircraft were flown by pseudopilots who used a keyboard to initiate changes in aircraft altitude, speed, and heading. In all runs, traffic was controlled by a single controller.

A total of five TRACON controllers participated in the evaluation. Three controllers were from the Denver TRACON, and the other two were recently retired from the San Francisco Bay TRACON. Each controller participated for a period of one week. Typically, one day of training runs was necessary before data were taken. In the case of the Denver controllers, training was considered completed in one-half

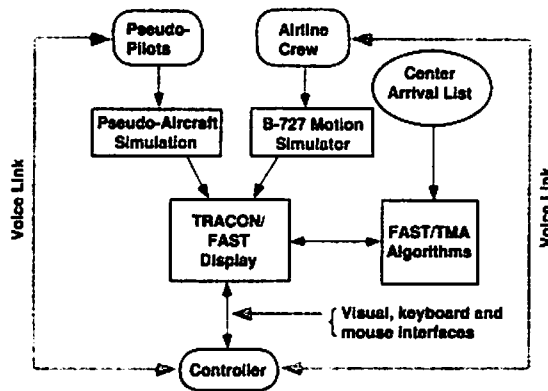

Fig. 4 Diagram of simulation configuration.

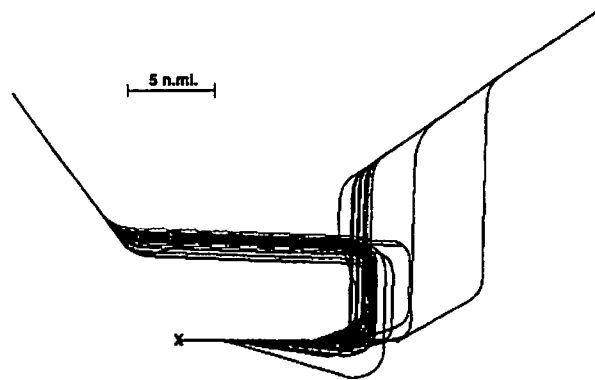

Fig. 6 Ground tracks for an automation run.

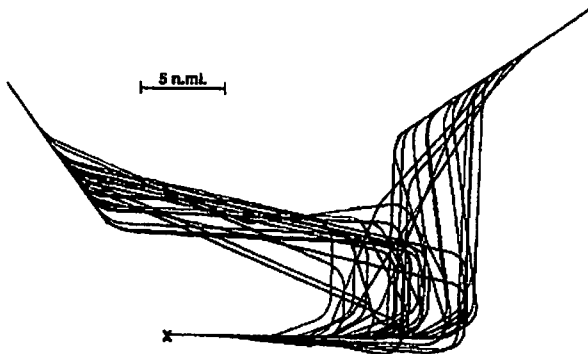

Fig. 5 Ground tracks for a baseline run.

day. Data runs were started when both the experimenter and controller agreed that proficiency had reached a high level. At the end of a simulation week, each controller was given a questionnaire and interviewed about the operational aspects of using the automation tools.

For the purposes described in this paper, two types of data runs were evaluated. The first was a baseline run in which the Center delivered traffic at the two Northern feeder gates, Drako and Keann, 7 n.m.i. in-trail and the TRACON controller had no automation tools to assist in merging and spacing traffic. The second was a full automation run in which the Center delivered traffic to the feeder gates using the Center automation tools, DA and TMA. In all of the data runs presented in this paper, the arrival rate was an average of 43 aircraft/h, which provided a flow at maximum runway acceptance rate for single runway 26L Instrument Flight Rules (IFR) operations at Denver. The arrival traffic rush lasted for 90 min, contained 70% large aircraft and 30% heavy aircraft, and distributed traffic evenly (50%/50%) between the two arrival gates (Keann and Drako). Winds were calm.

Simulation Results

Simulation results presented in this paper address the issues of airspace utilization, interarrival spacings, capacity effects, and controller evaluations.

Airspace Utilization

One of the primary measures of an automation tool for final approach spacing is airspace utilization. The composite ground tracks of aircraft for the two types of runs discussed earlier, baseline and FAST + DA + TMA, are shown in Figs. 5 and 6. The figures superimpose the horizontal plane projections of the flight paths of all arrivals recorded during a typical simulation run. These figures show traffic arriving from both the northeast (Keann) and northwest (Drako) feeder gates. The runway is located in the southwest quadrant of these figures and is marked with an X. The composite ground

tracks in both of these figures resulted from the same list of input traffic covering a time range of slightly more than 1h capacity limited flow (40–46 aircraft/h). They are representative of all other runs made by the other controllers.

In the baseline run (Fig. 5), the controller used considerably more airspace to merge and sequence traffic. By the end of the run, traffic had backed up such that he was turning the aircraft onto the final approach course 18 n.m.i. from the runway instead of the nominal 10 n.m.i. The length of the final approach allowed at Denver without having to coordinate with other controllers is approximately 20 n.m.i. from the runway. In the automation run (Fig. 6), almost all aircraft were turned to final at the nominal point between 10 and 11 n.m.i. from the runway. There were a few aircraft turned to base and final further out; however, this occurred at the advice of FAST in order to precisely alleviate potential conflicts and to build slots for aircraft that arrived in the TRACON off schedule. Although these aircraft were turned to base and final further from the runway, this did not cause a buildup in delay of trailing aircraft as would be the case in a manual system. Rather, it served to alleviate a buildup in delay, and kept each trailing aircraft on its nominal and shortest turn to base and final paths. The ability of the automation tools to precisely expand and contract the base and turn to final points provides considerable advantages to the controller. Assisting the controllers in keeping most aircraft on a short final allows them plenty of airspace to expand in case of an overload of traffic. In the baseline run, if an overload of traffic were to arrive, the controller would soon be forced to use alternative procedures to control the traffic, such as holding, sending traffic upwind then downwind (i.e., from the northeast arrival stream to the downwind portion of the northwest arrival stream), or to shut off the Center traffic feed for several minutes.

Interarrival Spacings

Data were also recorded on interarrival spacing of aircraft for both the baseline and automation runs. Tables 2 and 3 present the results of all runs with capacity limited flow rate for all controllers. These tables present the sequence of aircraft (L for large, H for heavy), mean interarrival distances at touchdown \bar{d} , one-sigma standard deviation of distance σ_d , mean interarrival time at touchdown, \bar{t} , and one-sigma standard deviation of time σ_t . As a point of reference, the desired distance separation for the LL and LH case is 3 n.m.i., and the scheduling interval for this case was 78 s. For the HL case, the desired distance separation is 5 n.m.i., and the scheduling interval was 125 s. Although the controllers were instructed to adhere strictly to the FAST advisories, no data were deleted for the few cases when the controller missed or ignored the advisories.

Table 2 contains values measured for the baseline case that are very similar to those measured for the manual system in Ref. 1. Table 3 shows a substantial decrease in interarrival spacing in both distance and time. The automation tool runs resulted in a decrease in mean distance separation of 0.4 n.m.i.

and a decrease in mean time separation of 9.8 s for the LL and LH case. Most significant is the decrease in the standard deviations of both distance and time separations seen in the tables. Similar results are seen for the HL case.

Capacity Effects

Based on these results, a rough estimate of increased capacity can be calculated. If all aircraft were large, the runway capacity for this simulation based on the scheduling interval of 78 s would be 46.2 aircraft/h. In the baseline runs, controllers delivered traffic at a rate of 38.8 aircraft/h based on the mean time separation. For the automation runs, the arrival rate was 43.4 aircraft/h. This implies a capacity increase of approximately 4.6 aircraft/h in the automation runs over the baseline runs.

An alternate method for estimating the capacity increase for the automation system is to make use of the empirically determined standard deviations in arrival time error. In this method, a time buffer is added to the minimum separation times such that all aircraft arriving within one sigma of the scheduling interval do not violate the minimum separation time standards (i.e., 78 s). It can be shown that the gain in arrival rate obtained by this method is 4.6 aircraft/h, which is consistent with the previous method. It should be noted that such an increase in landing rate, if realized in practice, would produce substantial delay reductions during rush periods.

Controller Evaluations

As described earlier, the controllers were given a questionnaire and interviewed at the conclusion of each simulation week. The questionnaire consisted of a set of statements regarding FAST. The controller was asked to rate each statement on a scale of 1-6, where 1 indicates strongly agree and 6 indicates strongly disagree. They were also encouraged to provide comments or explanations for any responses. There were 37 questions using this format followed by 6 summary questions such as; "What single feature would you add to the automation tool box considering the traffic you encountered in the simulation?" A sampling of responses to the questionnaire is given in Fig. 7.

The most important response was the strong agreement among all controllers that work load was reduced. This reduction in work load was manifested by a perceived reduction in the number of speed and heading clearances issued for each aircraft, as well as a perceived reduction in mental work load. Controllers found the time line useful for both sequence and schedule information. They said that the turn and speed advisories were easy to see, provided sufficient time to issue them, and usually coincided with what they would have done in sequencing aircraft. The questionnaire also showed that the speed and vector advisories were their favorite feature. When the advisories did not coincide with their own plan, they commented that the FAST generated plan was just as good and sometimes better. They did not find that additional vectoring was necessary beyond the FAST advisories, and they thought

Table 2 Interarrival data for baseline runs

Aircraft sequence	Number of occurrences	\bar{d}_i n.mi.	σ_{d_i} n.mi.	\bar{t}_i s	σ_{t_i} s
LL and LH	83	3.8	1.0	92.8	23.9
HL	21	5.6	1.5	127.8	29.8

Table 3 Interarrival data for automation runs

Aircraft sequence	Number of occurrences	\bar{d}_i n.mi.	σ_{d_i} n.mi.	\bar{t}_i s	σ_{t_i} s
LL and LH	125	3.4	0.7	83.0	17.0
HL	30	5.4	0.9	124.5	16.7

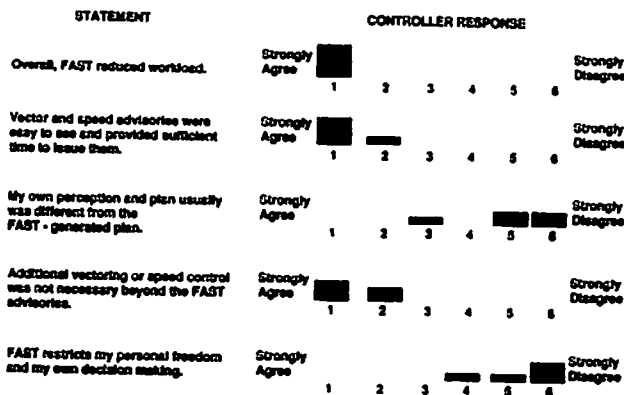

Fig. 7 Controller evaluation of the final approach spacing tool.

the tools were flexible and did not feel restricted in their own decision making.

Several suggestions were made for improving the controller interface, though none of the suggestions pointed to basic changes or major additional requirements in the interface design. Some controllers suggested a distance-based time line on which in-trail distance projected at the runway is displayed rather than time. Such a method has been used in the Center DA tool and could be adapted to the TRACON. Another suggestion was to give the controller an option to position the nominal downwind and base leg at his or her discretion, and to incorporate certain controller preferences in the advisory logic. These and other suggestions are being considered for incorporation into FAST.

Finally, all of the controllers expressed strong support for the integrated terminal automation system concept composed of Center DA and TMA and TRACON FAST.

Concluding Remarks

The automation tools described in this paper and evaluated in the simulation were designed primarily for Terminal radar approach controllers. However, the Center automation tools that were used to feed traffic into the Terminal area played an important role in the success of the Terminal automation tools. The Center tools were effective in delivering traffic to the feeder gates well sorted and with little time error, thus simplifying the Terminal controller's job with or without automation tools. Therefore, a total systems approach that integrates Center and Terminal area automation tools is clearly the best method to increase efficiency.

The simulation evaluation of the Final Approach Spacing Tool demonstrated efficient airspace utilization and reduced interarrival separations and resulted in strong controller acceptance of the automation tools. With the Final Approach Spacing Tool, controllers were consistently able to maintain final approach intercepts of 10-11 n.mi. from the runway for over 1 h of runway-capacity-limited arrival traffic. Without the automation tools, final approach intercepts were expanded to 18-20 n.mi. In addition, the mean interarrival separations were reduced by 0.4 n.mi or 9 s. This reduction in separation translates to an increase in landing rate of 4.6 aircraft/h for a single runway in Instrument Flight Rule conditions. Finally, all of the controllers found a significant decrease in work load, which was manifested by a perceived reduction in clearances as well as a perceived reduction in mental work load.

Further simulation evaluations of the Final Approach Spacing Tool are planned in the near future. These will address such issues as testing the Terminal area automation tools stand-alone without the Center automation tools, descent advisor and traffic management advisor, and under varying wind conditions. In addition, further simulations studies of mixing flight-path management system equipped aircraft and conventionally equipped aircraft will be conducted. Ultimately, however, a test of the concept in the Denver Terminal area or a

similar facility must be conducted in order to establish the effectiveness of the tools with a high level of confidence.

References

- ¹Martin, D. A., and Willet, F.M., "Development and Application of a Terminal Spacing System," Federal Aviation Administration, Rept. NA-68-25 (RD-68-16), Aug. 1968.
- ²Volckers, U., "Computer Assisted Arrival Sequencing and Scheduling with the COMPAS System," *Proceedings of the 1986 AGARD Conference No. 410 on Efficient Conduct of Individual Flights and Air Traffic*, Brussels, Belgium, 1986, pp. 54-1-54-11.
- ³Volckers, U., and Schenk, H. D., "Operational Experience with the Computer Oriented Metering Planning and Advisory System (COMPAS) at Frankfurt, Germany," AIAA Paper 89-3627, Aug. 1989.
- ⁴Credeur, L., and Capron, W. R., "Simulation Evaluation of TIMER, a Time-Based, Terminal Air Traffic, Flow Management Concept," NASA TP-2870, Feb. 1989.
- ⁵Erzberger, H., and Nedell, W., "Design of Automated System for Management of Arrival Traffic," NASA TM-102201, June 1989.
- ⁶Davis, T. J., Erzberger, H., and Bergeron, H., "Design of a Final Approach Spacing Tool for TRACON Air Traffic Control," NASA TM-102229, Sept. 1989.
- ⁷Neuman, F., and Erzberger, H., "Analysis of Sequencing and Scheduling Methods for Arrival Traffic," NASA TM-102795, April 1990.
- ⁸Tobias, L., "Time Scheduling of a Mix of 4D Equipped and Unequipped Aircraft," *Proceedings of 22nd IEEE Conference on Decision and Control*, Inst. of Electrical and Electronics Engineers, Piscataway, NJ, Dec. 1983, pp. 483-488.
- ⁹Erzberger, H., and Tobias, L., "A Time-Based Concept for Terminal Area Traffic Management," *Proceedings of the 1986 AGARD Conference No. 410 on Efficient Conduct of Individual Flights and Air Traffic*, Brussels, Belgium, 1986, pp. 52-1-52-14.
- ¹⁰Erzberger, H., and Lee, H. Q., "Optimum Horizontal Guidance Techniques for Aircraft," *Journal of Aircraft*, Vol. 8, No. 2, 1971, pp. 95-101.
- ¹¹Erzberger, H., and McLean, J. D., "Fuel Conservative Guidance System for Powered Lift Aircraft," *Journal of Guidance and Control*, Vol. 4, No. 3, 1981, pp. 253-261.
- ¹²Tobias, L., Erzberger, H., Lee, H. Q., and O'Brien, P. J., "Mixing Four-Dimensional Equipped and Unequipped Aircraft in the Terminal Area," *Journal of Guidance, Control, and Dynamics*, Vol. 8, No. 3, 1985, p. 296.